



INSTRUCTIONS FOR USE

Pro-Ject 9

Pro-Ject 9c

Pro-Ject 9cc

Pro-Ject 10cc

Pro-Ject 12cc

- 1 Finger lift *
- 2 Headshell
- 3 Tonearm tube
- 4 Tonearm rest
- 4a Removable transport lock
- 5 Tonearm lift lever
- 6 Anti-skating weight support hoop *
- 7 Anti-skating weight *
- 8 Tonearm counterweight *
- 8a Downforce scale
- 9 Anti-skating weight adjustment scale
- 10 Tonearm base *

Drilling template for mounting tonearm base *

Fixing screw for the anti-skating-weight (1x 6mm M3)*

Tonearm base fixing bolts (3x 12mm M5) *

Wood screws to fix the RCA/phono socket box (2x 2,9 x 9,5) *

2x hexagon keys: 1,5mm and 3mm *

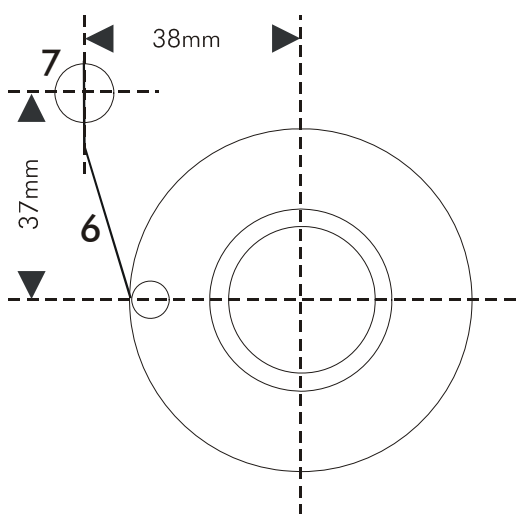
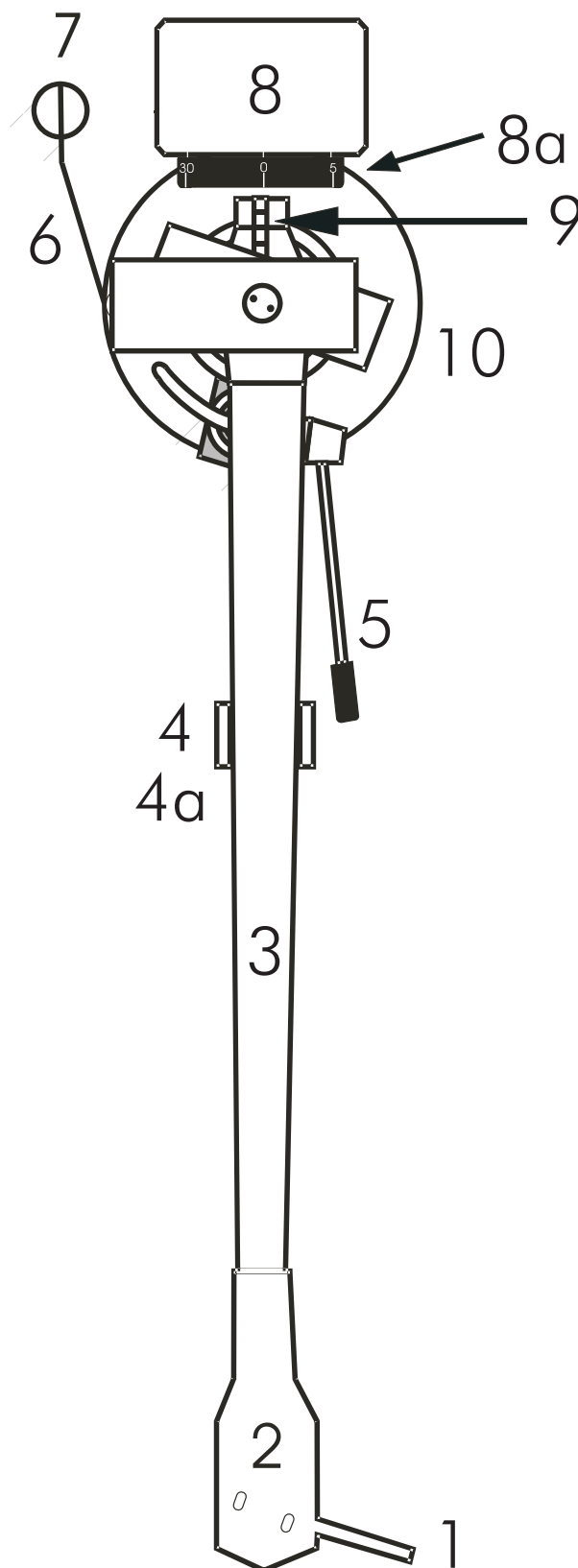

Dear music lover,
thank you for purchasing a PRO-JECT AUDIO tonearm.

In order to achieve maximum performance and reliability with this record player you should study these instructions for use carefully.



Important notice.

During assembly and adjustment small parts could be lost if not carefully placed in a suitable receptacle. Before starting assembly make yourself acquainted with the parts listed above and correspondingly numbered in the technical drawings above. Separately packed items are marked with an asterisk *.

Replacement of a tonearm on Pro-Ject turntables with RCA phono sockets.

Remove the anti-skating (7) and counterbalance weight (8). Remove the screws retaining the socket bracket on the underside of the plinth. De-solder all wires. After loosening the two hexagon screws in the base (10) the tonearm may be carefully pulled up and out of the base (10).

Fit the new tonearm as above but in reverse order. Adjust the arm height and azimuth as described on pages 4.

Fitting tonearms from other manufacturers

Lay the enclosed template over the platter spindle. Mark the centers for the mounting hole and the three screwholes with a sharp tool. Whilst aligning the template please take note that the two hexagon grub screws in the base (10) must be aligned at 10 and 2 o'clock. Make sure there is sufficient room to the rear and side of the arm base (10) for the arm to turn without hindrance when the lid is closed.

After drilling the holes and cleaning up the edges screw the arm base (10) to the mounting surface with the three bolts. The two hexagon grub screws in the base (10) should be aligned at 10 and 2 o'clock.

Next, determine the correct position for the anti-skating weight support (6). Fit the support (6) to the arm base (10). The anti-skating weight (7) must end up in the position shown on page 2.

Lead the internal wiring out through the hole in the arm base, then connect it to the output sockets of your record player, or to the RCA/phono socket box supplied with the tonearm. The socket box must then be attached to a suitable place on the turntable plinth. Finally, adjust the arm height and azimuth as described on pages 4.



The Pro-Ject 9, 9c and Pro-Ject 9cc tonearms fit all turntables which use the Linn mounting standard.

No soldering is required for tonearms fitted with a standard 5-pole connector socket. Just connect the tonearm leadout to the 5-pole socket.

Fitting and connecting the cartridge

All cartridges with half inch mounting holes can be fitted. Leaving the needle's protection cover on, fit the cartridge to the headshell (2) using the screws supplied with the cartridge by passing one screw through each slot in the headshell (2). Do not tighten the nuts yet. Connect the tonearm wires to the cartridge pins as follows:

white	left channel positive (L+)
red	right channel pos. (R+)
green	right channel return (R -)
blue	left channel return (L -)

The full sound quality of the PRO-JECT tonearms can only be achieved if the cartridge is correctly adjusted. Particular tools like the PRO-JECT alignment tool are required to accomplish this job properly. If you are not well acquainted with the adjustment of cartridges you are advised to call upon the willing help of your PRO-JECT dealer to accomplish this task for you.



*Models Pro-Ject 9 and Pro-Ject 9c. The finger lift (1) must be fitted on top of the headshell under the cartridge fixing bolts or nuts - **not** between headshell and cartridge body.*

Please note: adjusting a cartridge and tonearm calls for the greatest care in order to avoid damaging the cartridge or tonearm bearings. Leave this work to your dealer if you are in any way unsure of the necessary steps and precautions to be taken.

Cartridge downforce adjustment

Remove the transport lock (4a) from the tonearm tube (3). Store it in the original packaging so they are available for any future transportation.

Pushing carefully, turn the counterweight (8) onto the rear end of the tonearm tube (3), so that the downforce scale (8a) shows towards the front of the player. Lower the armlift and position the cartridge in the space between arm rest and platter. Carefully rotate the counterweight (8) until the armtube balances out. The arm should return to the balanced position if it is moved up or down. This adjustment must be done carefully. Do not forget to remove the cartridge protection cap if fitted.

Once the arm is correctly balanced return it to the rest. Hold the counterweight (8) without moving it, and gently revolve the downforce scale ring (8a) until the zero is in line with the anti-skating prong (9). Check whether the arm still balances out.

Rotate the counterweight counter clockwise (seen from the front) to adjust the downforce according to the cartridge manufacturer's recommendations. One mark on the scale represents 1 mN (= 0,1g / 0,1 Pond) of downforce.



Adjust the downforce prior to installing the anti-skating weight.

For further information on supplied and optional counterweights see the last page.

Adjusting the azimuth

The cartridge needle must be vertical in the record groove in order to trace the groove wall modulations correctly.

A small screw at the bearing end of the arm tube (3) allows incorrect azimuth to be corrected if your needle is not mounted exactly perpendicular to the cartridge body (which is often the case).

Slacken off the screw just enough to be able to revolve the arm tube (3) without applying force. Note! Do not remove the screw completely!

With the aid of a good magnifying glass adjust the needle until it is vertical in the groove (i.e. perpendicular to the record's surface). Ideally this should correspond to the top surface of the cartridge body being parallel to the record surface, but in practice this is often not the case.

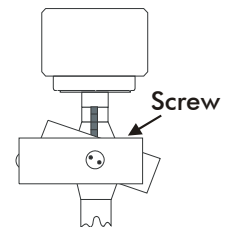

Under no circumstances should the arm tube be adjusted with the needle still in the record groove! Irreparable damage may be caused to the cantilever suspension! The arm must be lifted to make each adjustment and lowered afterwards to check it.

Anti-skating force adjustment

The anti-skating force must be adjusted according to the mass of the cartridge as follows:

Pro-Ject 9, Pro-Ject 9c, Pro-Ject 9cc and Pro-Ject 10cc

Downforce	Groove in the stub (9)
10 - 14mN	1 st from bearing rings
15 - 19mN	2 nd " " "
20mN and bigger	3 rd " " "

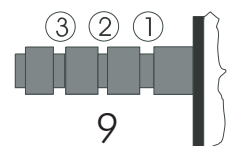

Pro-Ject 12cc

Downforce	Groove in the stub (9)
8 - 11mN	1 st from bearing rings
12 - 14mN	2 nd " " "
15mN and bigger	3 rd " " "

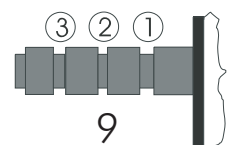

Hang the loop of the thread of the anti-skating weight (7) in the groove of the anti-skating stub (9) corresponding to the downforce applied to your cartridge and feed the thread through the loop of the wire support (6).

Adjusting the vertical tracking

Put a record on the platter. When the needle is lowered into the record groove and the tonearm is not resting on the lift arm, the arm tube (3) of the tonearm should be parallel to the surface of the record.

If it is not loosen both hexagon screws in the tonearm base (10) just enough to allow vertical movement of the arm pillar without force and slide the arm up or down until it is parallel.

Carefully retighten both hexagon screws without applying excessive force (which would deform the arm pillar) – finger tight is quite sufficient.

Service

Should you encounter a problem, please contact your dealer for further advice. Only when the problem cannot be resolved there should the unit be sent to the responsible distributor in your country.

Never return a tonearm without making sure that it is safely disassembled and correctly packaged in the original packaging. Guarantee repairs will only be effected if the unit is returned correctly packaged. For this reason we recommend keeping the original packaging.

Please remove these parts and pack them separately: tonearm base (10), counterweight (8), anti-skating weight (7), anti-skating weight support hoop (6) and cartridge. Insert the transport lock for the tonearm (4a) prior to carefully packaging the tonearm.

PRO-JECT is a Registered Trademark of H. Lichtenegger. The information was correct at the time of going to press. The manufacturer reserves the right to make changes to the technical specification without prior notice as deemed necessary to uphold the ongoing process of technical development.

This guide was produced by: Audio Trade GmbH
Copyright © 2008. All rights reserved.

Technical specifications

1" = 2,54cm

	Pro-Ject 9	Pro-Ject 9c	Pro-Ject 9cc	Pro-Ject 10cc	Pro-Ject 12cc
Headshell 0,5" standard:	✓	✓	✓	✓	✓
Mounting distance arm base	212mm	212mm	212mm	238mm	291,6mm
Armtube made of	aluminium	carbon-fibre	carbon-fibre	carbon-fibre	carbon-fibre
Headshell made of	aluminium	aluminium	carbon-fibre	carbon-fibre	carbon-fibre
Eff. tonearm length	9"	9"	9"	10"	12"
Eff. tonearm mass	11g	11g	8,5g	9g	10,5g
Overhang	18mm	18mm	18mm	16mm	13,2mm
Supplied counterweights for cartridge weights	6 - 14g (no. 3)	6 - 9g (no. 2)	6 - 10g (nr. 16)	6 - 9g (no. 2)	4 - 6g (no. 2)
counterweight no. ()	-----	-----	-----	-----	7 - 9g (no. 3)
Optional counterweights for cartridge weights	2 - 6g (no. 9)	4 - 6g (no. 9)	3 - 6g (no. 7)	2 - 5g (no. 9)	9,5 - 13g (no. 4)
counterweight no. ()	4 - 10g (no. 2)	9 - 11g (no. 23)	5 - 8g (no. 9)	7 - 11g (no. 3)	-----
	10 - 16g (no. 4)	10 - 15g (no. 3)	11 - 15g (no. 3)	10 - 15g (no. 4)	-----
Downforce range	10 - 35mN	10 - 35mN	10 - 30mN	10 - 35mN	10 - 35mN
Weight (without counterweight)	250g	250g	250g	254g	257g



All tonearms are available either with flying leads terminated with a 5-pole standard tonearm socket, or with a cable terminated with RCA phono sockets.